

## LAZER TRIPLE-R SERIEN

### ELEKTRISK KOPPLING/ ELECTRICAL CONNECTION

#### TRIPLE-R (ej/excl. PL,16, 24, 28)

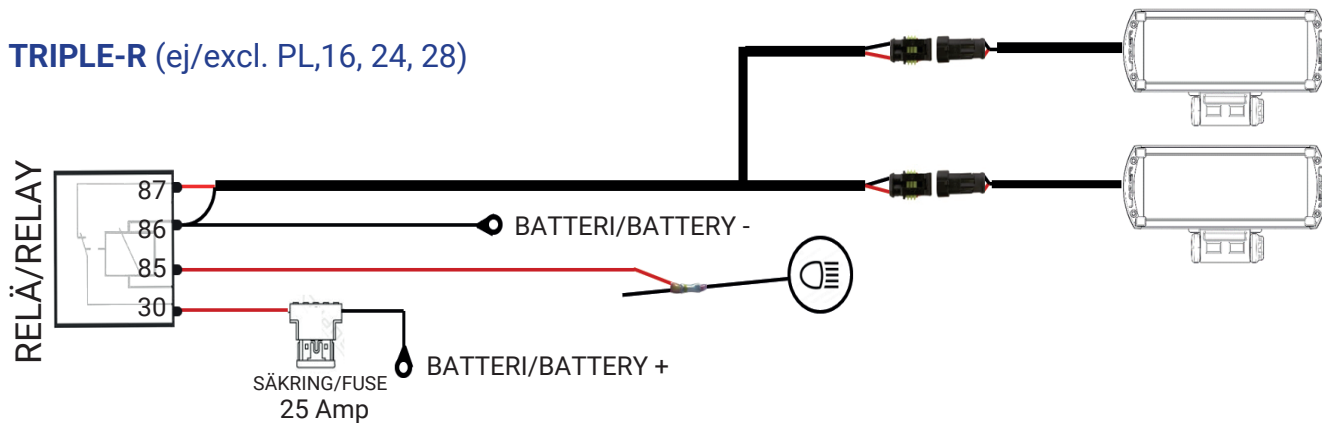

#### TRIPLE-R 16, 24, 28

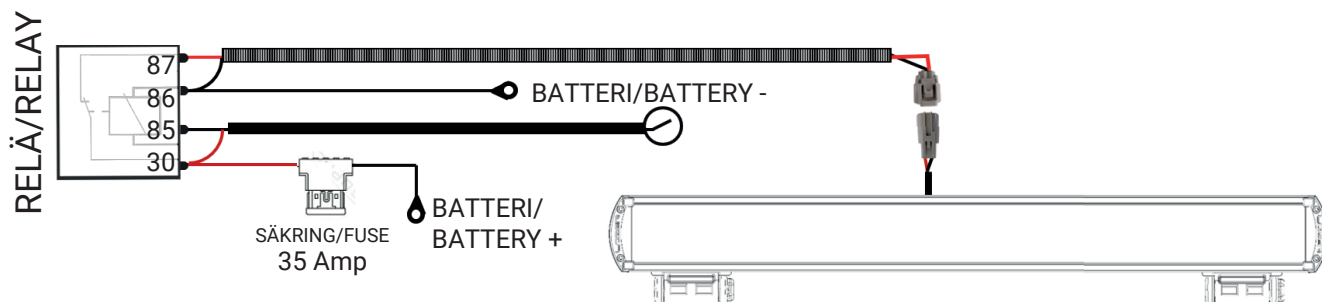

#### TRIPLE-R med positionsljus/with position light

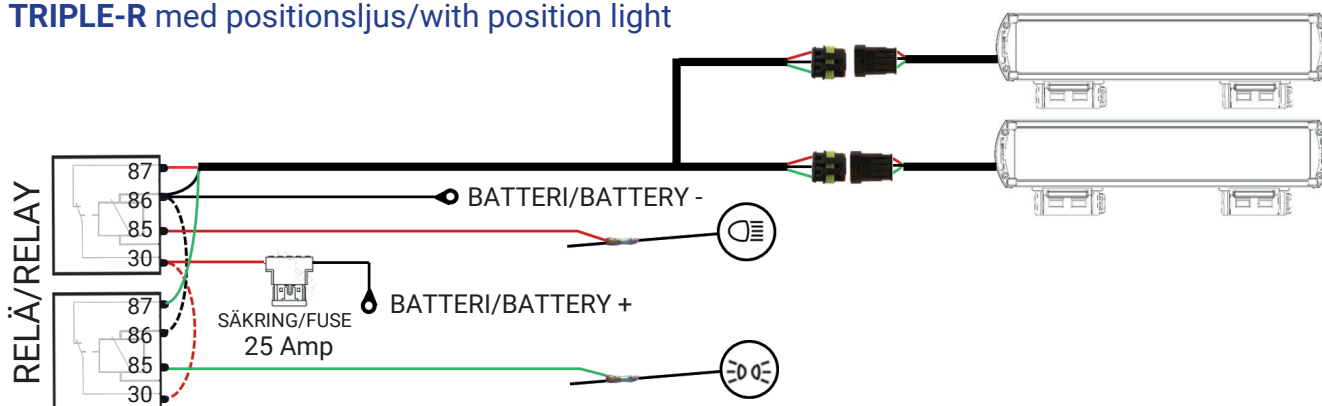

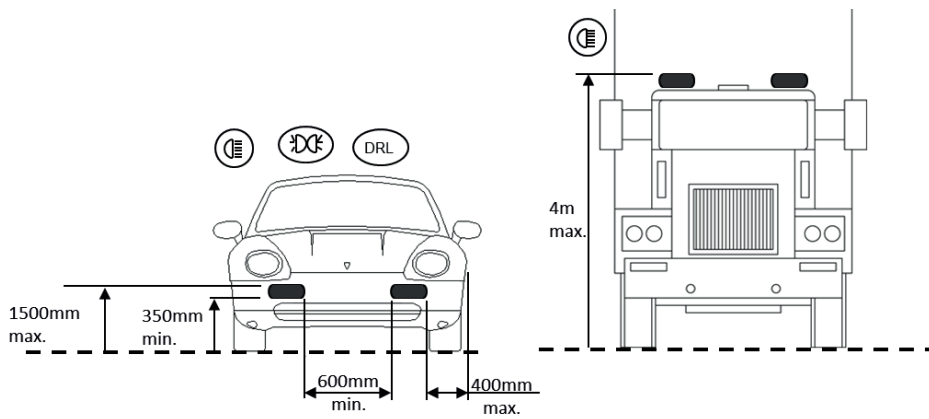

**SE** - För extraljusramper och positionsljus gäller vissa regler. Bilden visar de rätta placeringarna av ljusrampen.

**EN** - Lamps with integrated DRL and Position light must be positioned according to the above sketch. If an additional pair of position lights is not permitted (e.g. in Switzerland, Austria), the position light should be disconnected. The legal regulations in individual countries must be observed.